



ISO9001:2008 Certified  
ISO14001:2004 Certified

# TOYO KOKEN BABY HOIST®

This is the market-leading hoist in Japan.

- BABY HOIST is a portable, compact and lightweight hoist.
- Installation of the hoist is just to hang it.
- It can lift heavy loads up easily.
- The machine can work in two-speed: high speed and low speed, and adjust the position of loads easily.
- Slow start enable work with loads moving slightly.

## BH-800A Series

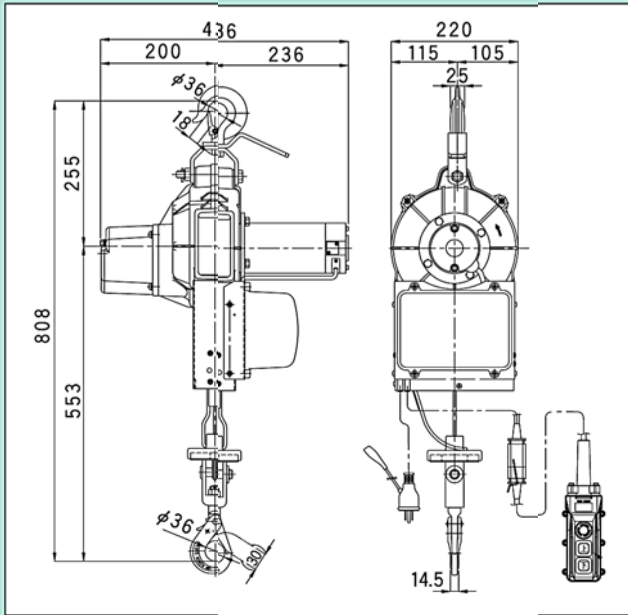

## BABY HOIST BH-800A series



BH-800A



Push button switch

### ■ Distinctive features by extensive devices.

#### Brakes

Combination of our unique mechanical load brake and dynamic brake enables loads to stop surely.

#### Slip clutch

Slip clutch protects the machine when loads are caught and impact loading occurs.

#### Over-winding protector

It prevents wire rope from breaking and the machine from breaking down by over-winding.

#### Reverse winding protector

It detects wire rope loosening and reverse winding caused by irregular winding, and stops the machine automatically. Meanwhile, when wire rope is wound reversely, brakes are disabled.

#### Emergency stop button

An emergency stop button enables the machine to stop even if something wrong happens to it.

#### Wire rope

Our unique long-life wire rope is wound onto a drum.

#### Bottom hook

It is a self-locking hook which is automatically locked when loads are placed on it. It surely prevents loads from falling off.

#### Plugging prevention function

The circuit preventing reverse operating doing damages to the machine is also installed.

### ■ Specifications

Model	BH-815A	BH-820A	BH-830A
Rated Load (kg)	250	230	180
Hook Path (m)	15	20	30
Lifting Speed (1st / Last Layer) (m/min)	High	9 / 11	9 / 12
	Low	2.9 / 3.2	3 / 3.7
Motor Output (W)	600		
Weight (kg)	Main Body	18	
	Accessories	4.5	5.1

Power source : Single Phase AC200~240V 50/60Hz

Shop



## TOYO KOKEN K.K.

2-11-1, Minamisuna, Koto-ku, Tokyo 136-8666 JAPAN

TEL+81-3-5857-3161 FAX+81-3-5857-3198

E-mail: koken-os@toyokoken.co.jp



H.P

Factory

YAMANASHI PLANT TEL+81-55-282-5581 FAX+81-55-284-2398

For the latest information on products, see at <http://www.toyokoken.co.jp/en/>

**Caution** For correct and safe operation, be sure to read the "Operation Manual" before starting the equipment.